

B. A. T.
Basic Appliance Training

BASIC REFRIGERATION

presented by
Jim Campbell, Mcap

Program Objective

The objective of this program is to give you some of the basic elements that are essential to understanding refrigeration systems and start you on the path to learning refrigeration servicing.

This program will not be sufficient for you to totally understand all aspects of refrigeration servicing but will lay a foundation for you to build on from other training sessions and practical learning through on-the-job training.

Program Outline

- **Safety**

- **Refrigeration**
 - **Fundamentals of Refrigeration**
 - **The Refrigeration Cycle**
 - **Pressures in the system**
 - **Theory of Heat**

- **The Refrigeration System**
 - **Refrigeration System Components**
 - **System Component Servicing**

- **Refrigerants**

- **Refrigeration System Troubleshooting**

- **EPA & Refrigerant Recovery overview**

SAFETY

With SAFETY, there are three main areas of concern:

1. Your personal safety
2. Customer's safety
3. Safety of the equipment

Specific Safety concerns when working in the refrigeration or air conditioning field.

- Do not heat cylinders with a torch.
- Use caution when working with an open flame
- Fluorocarbon refrigerants, if exposed to a flame, will produce Phosgene gas which is toxic
- Exposure to liquid refrigerant will cause frostbite
- Refrigerant oil from a burned-out compressor may be acidic and cause a burn
- NEVER pressurize a system with oxygen or compressed air
- Do not breath in refrigerant or release it into the atmosphere
- Restrain refrigerant cylinders during transportation
- Practice "Lock-Out / Tag-Out" & protect yourself from electrical shock, Use your Personal Protective Equipment (PPE)
- Be sure to wear safety glasses and any other Personal Protective Equipment (PPE) while performing service work
- De-Energize, Lock-Out, and Tag Equipment before removing guards to service rotating components
- Remove watches and other jewelry before servicing equipment

REFRIGERATION

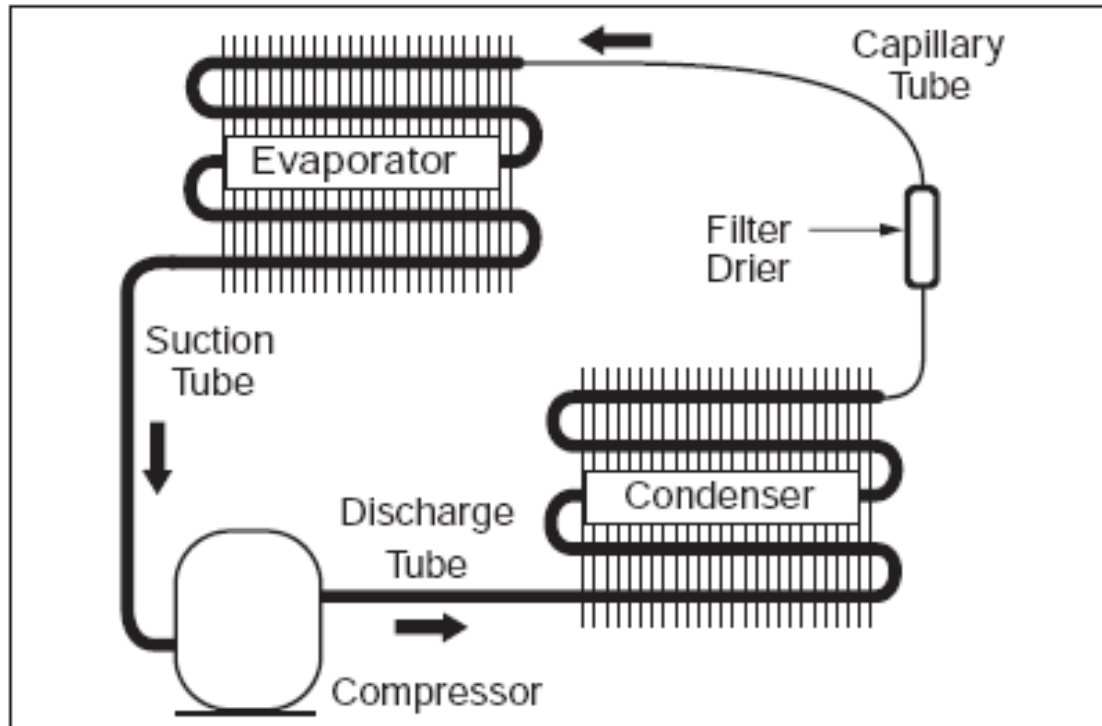

Refrigeration is actually the removal of heat to produce a cooling effect. Cold cannot be produced, heat has to be removed and the absence of heat is cold. In the refrigeration process heat is moved from a space where it is not wanted to a space where it is less-objectionable.

The process of refrigeration is most commonly accomplished by the evaporation of a liquid refrigerant, thereby extracting heat from the area to be cooled.

During this training we will be focusing on the compression type refrigeration system. The compression type refrigeration system utilizes a pump called a compressor to move a medium, refrigerant, throughout a closed system of piping and other components.

Fundamentals of Refrigeration

The refrigeration cycle:

The refrigeration cycle is a continuous cycle that occurs whenever the compressor is in operation. Liquid refrigerant is evaporated or vaporized in the evaporator by heat that enters the cabinet through the insulated walls and by the heat from product load (food) and door openings. The refrigerant vapor is then drawn from the evaporator, through the suction line, to the compressor.

Compression raises the pressure and temperature of the vapor in the compressor and the vapor is then forced through the discharge valve into the discharge line and into the condenser. Air passing over the condenser surface removes heat from the high pressure vapor which then condenses to a liquid. The liquid refrigerant then flows from the condenser to the evaporator through the small diameter liquid line (capillary tube).

Before it enters the evaporator, the liquid refrigerant is sub-cooled in the heat exchanger by the low temperature suction vapor in the suction line. When refrigerant is added, the frost pattern will improve, the suction and discharge pressures will rise, the condenser will become hot and the wattage will increase.

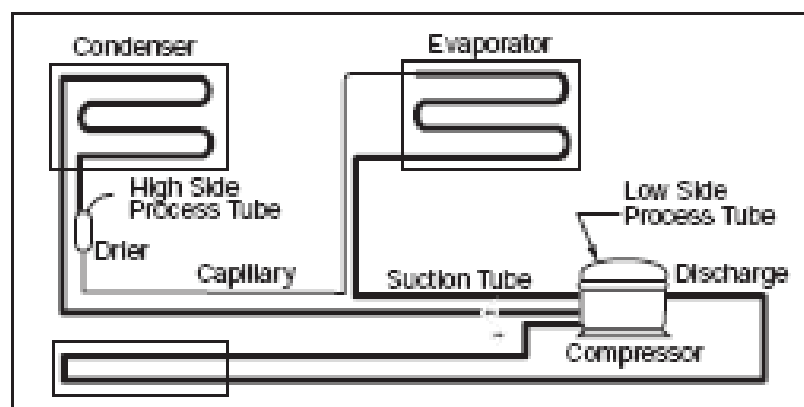

Pressures in the system:

The refrigeration system is usually divided into two main sections based on the operating pressure within that section. Each individual section would have various components within that section.

The sections are identified as; the **High** side which is that part of the system from the outlet of the compressor to the inlet of the metering device and the **Low** side which is that part of the system from the outlet of the metering device to the inlet side of the compressor.

The metering device and the compressor are actually in both sides of the system because they are the dividing lines between the two pressure environments.

The entire operation of the refrigeration system depends on the pressure that is inside the system and the actual pressure differential between the **High** side and **Low** side of the system.

Now that we have established a High side and Low side based on the pressure inside the system;

what is pressure? *Force applied uniformly over a surface.*

what does pressure have to do with refrigeration? *By controlling the pressure applied to the refrigerant in various parts of the system, we can control the characteristics of the refrigerant. We can make it boil or we can make it condense.*

what are the different types of pressure?

Atmospheric Pressure

Gauge Pressure

Absolute Pressure

Atmospheric pressure:

Atmospheric pressure is that pressure which is exerted by the atmosphere in all directions. Standard atmospheric pressure is considered to be 14.695 Lb / sq in (PSI) at sea level.

Gauge pressure:

Gauge pressure is that pressure in addition to atmospheric pressure. It is the usual reading in psi obtained on a gauge that reads zero when disconnected from any pressure source.

Absolute pressure:

Absolute pressure is the sum of gauge pressure and atmospheric pressure at any particular time. For example, if the pressure gauge reads 53.7 psi, then the absolute pressure is 53.7 + 14.7 (atmospheric pressure) or 68.4 psia.



Since we have a basic idea of pressure, what importance does it play in the process of refrigeration and the removal of heat?

By controlling the pressure applied to a substance we can control its vaporization temperature (boiling point) and its condensation temperature (point of fusion). By controlling its BP and FP, we can control its ability to absorb and release heat.

Now let's take a closer look at heat itself.

Theory of Heat:

Heat associated with a refrigeration system is a vital part of the entire refrigeration system operation. As stated earlier, heat is moved from one place to another to cause the refrigeration or air conditioning effect.

Because heat is so important in a refrigeration or air conditioning system, it is important to understand heat and its properties and characteristics.

The intensity of heat within a substance or body is measured by temperature using a thermometer however the quantity of heat within a substance or body is not measurable with a thermometer. The quantity of heat is measured in BTUs.

What is a BTU?

A **BTU** is described as the amount of heat required to raise the temperature of 1 lb of water 1 degree F.

The three types of heat that are relative to a refrigeration or air conditioning system is:

1. **Specific** heat, which is the amount of heat required to raise the temperature of one pound of a substance 1 degree F.
2. **Sensible** heat, which is the amount of heat that can be felt or measured with a thermometer.
3. **Latent** heat, which is the heat that brings about a change of state with no change in pressure or temperature. This is normally referred to as *hidden* heat and cannot be measured with a thermometer.

Theory of Heat cont.

The following are examples of the application of heat with an example using Ice at 0° F raised to Steam at 250 ° F.

Raise the temperature of 1 lb of ice at 0 degrees F to ice at 32 degree F. **_Sensible_**

Cause the 1 lb of ice to melt delivering 1 lb of water with no change in temperature. **_Latent_**

Raise the temperature of 1 lb of water from 32 degrees F to water at 212 degrees F. **_Sensible_**

Cause the 1 lb of water at 212 degrees F to vaporize to steam at 212 degrees F. **_Latent_**

Raise the temperature of 1 lb of steam at 212 degrees F to steam at 250 degrees F. **_Sensible_**

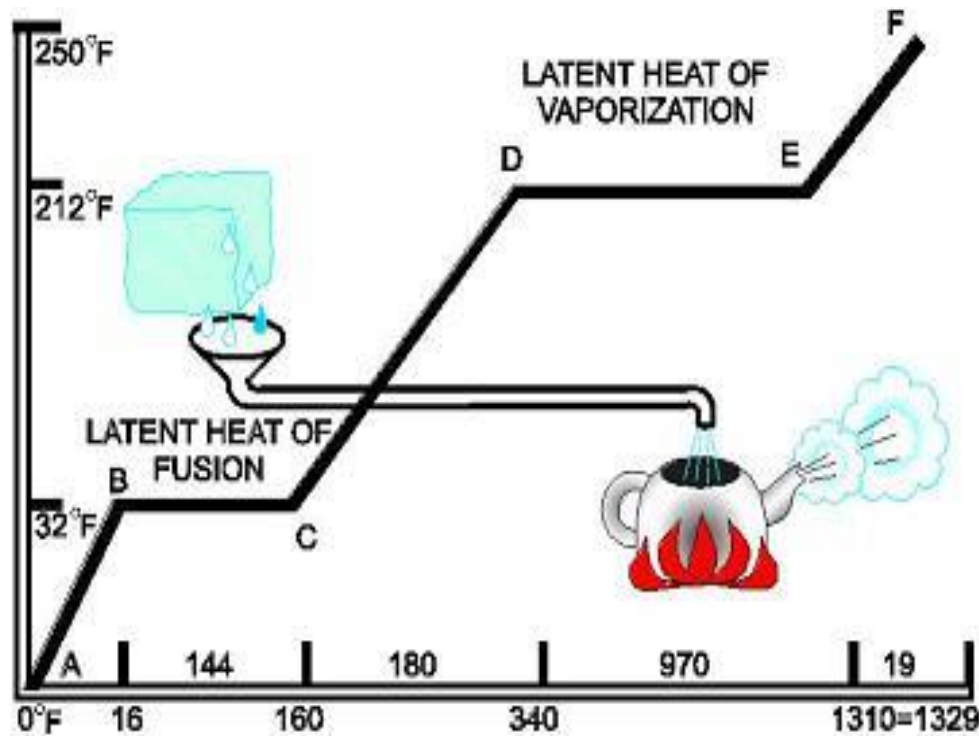

Theory of Heat cont.

In the process of refrigeration or air conditioning, we are actually going in reverse of this example. The refrigeration or air conditioning system would be removing the heat from the products in a refrigerator / freezer or removing the heat from air for air conditioning and also condensing moisture for de-humidification.

In a refrigeration or air conditioning system, heat is transferred by one of three methods, they are;

1. **Conduction** _____ which is direct contact with the product.
2. **Radiation** _____ which is no direct contact with the product.

3. Convection which is transferred by the movement of a medium or carrier.

All three methods are used during the refrigeration or air conditioning process.

The Refrigeration System

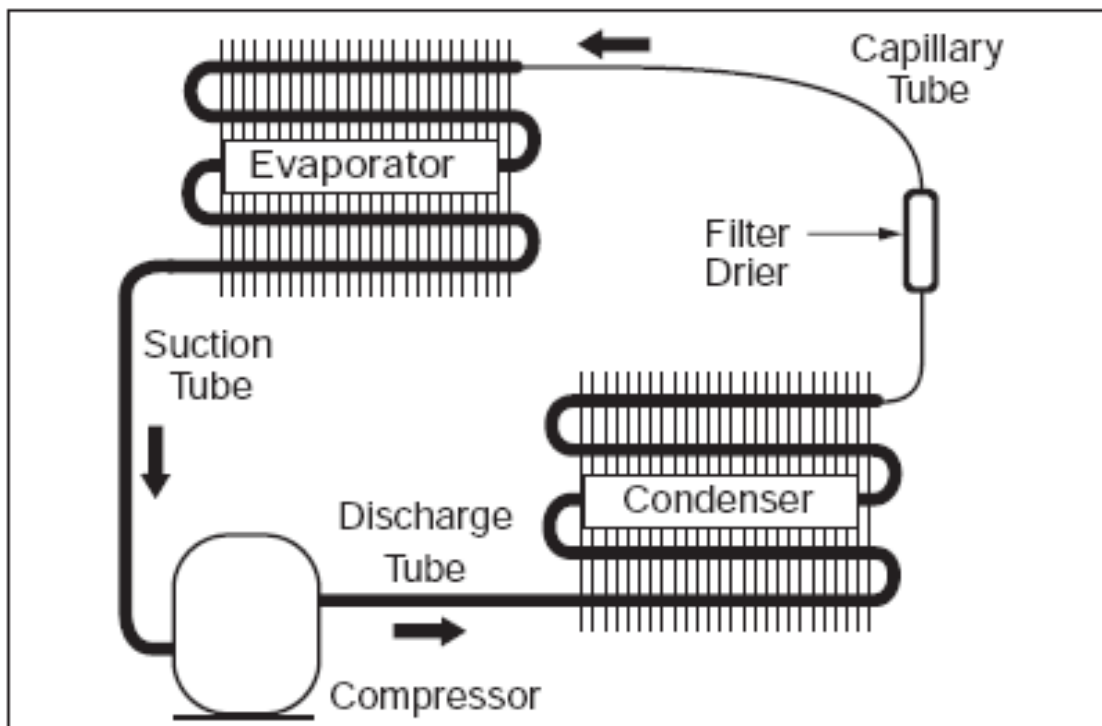

The picture above is a layout of a simple refrigeration system representative of the basic components that make up a closed loop compression type refrigeration system.

No matter how elaborate the system, the same basic principle of operation still exists.

The four main components that make up a simple refrigeration system are:

- 1. Compressor**
- 2. Condenser**
- 3. Evaporator**
- 4. Refrigerant metering device**

Now we'll take a closer look at these components and how they operate.

Refrigeration System Components

- 1. COMPRESSOR:**

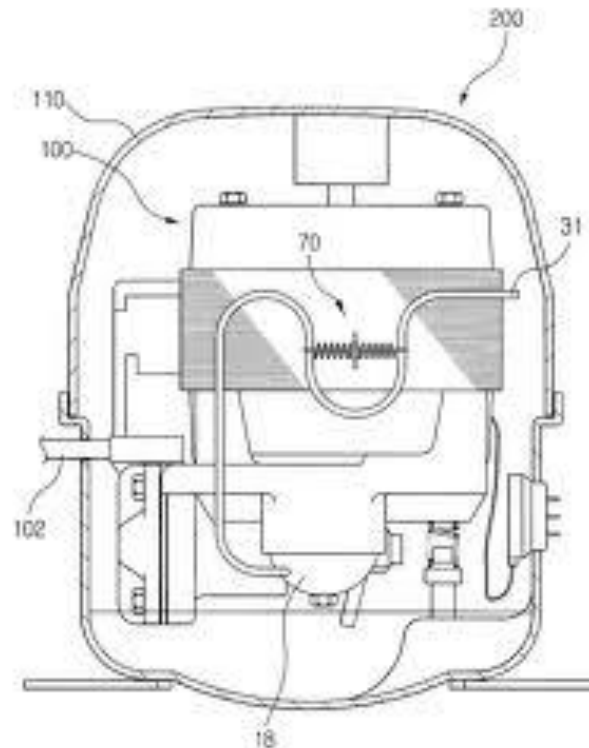

The compressor pumps the refrigerant through the entire system. It draws vapor refrigerant from the Evaporator which creates a Low-Pressure (suction) on the part of the system downstream from the metering device.

The compressor pulls in cool low-pressure vapor from the evaporator, compresses it, then pushes out a high-pressure superheated vapor to the condenser.

There are two general types of compressors used in refrigerator / freezers, Reciprocating and Rotary; three general types used in Air Conditioning, Reciprocating, Rotary and Scroll. The Scroll is similar to a rotary compressor.

Compressors:

There are two general types of compressors used in refrigerator / freezers, Reciprocating and Rotary.

There are three general types of compressors used in Air Conditioning, Reciprocating, Rotary and Scroll. The scroll is kind-of like a rotary compressor, but different.

- Typical Refrigerator / Freezer compressors:

Reciprocal

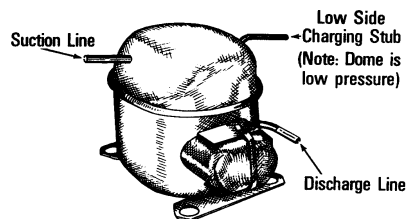

Rotary

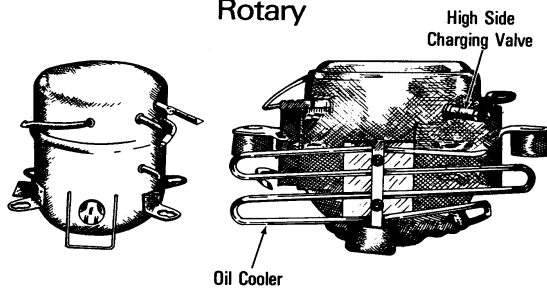

- Air Conditioning compressors



2. CONDENSER:



The condenser acts similar to a radiator on a car; it cools the refrigerant which allows it to give off heat. As the refrigerant cools it condenses to a liquid. The liquid refrigerant is then pushed on to the metering device.

The condenser performs de-superheating by cooling the vapor which lowers its temperature slightly but more importantly allows the removal of latent heat (discussed later) which allows the refrigerant to change from a vapor to a liquid.

Condensers:

There are about three different types of condensers that you will encounter in the residential market:

1. Forced - Draft
2. Static
3. Warm-Wall

Refrigerator / Freezer condensers:

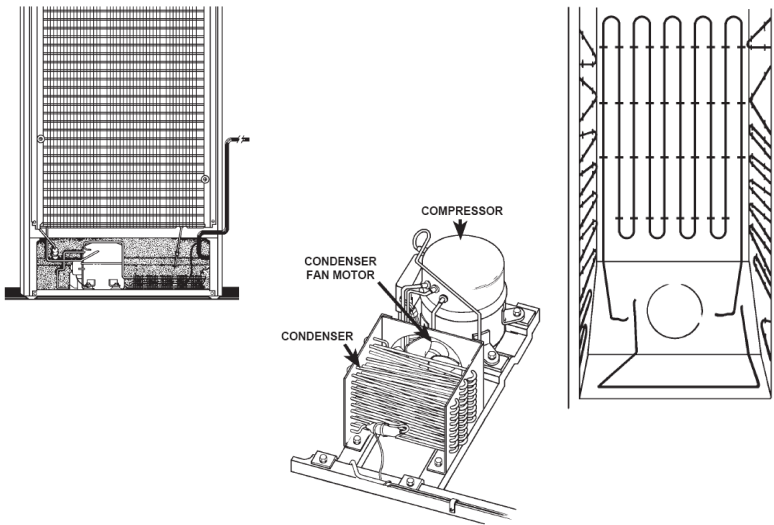

Air Conditioning condensers:

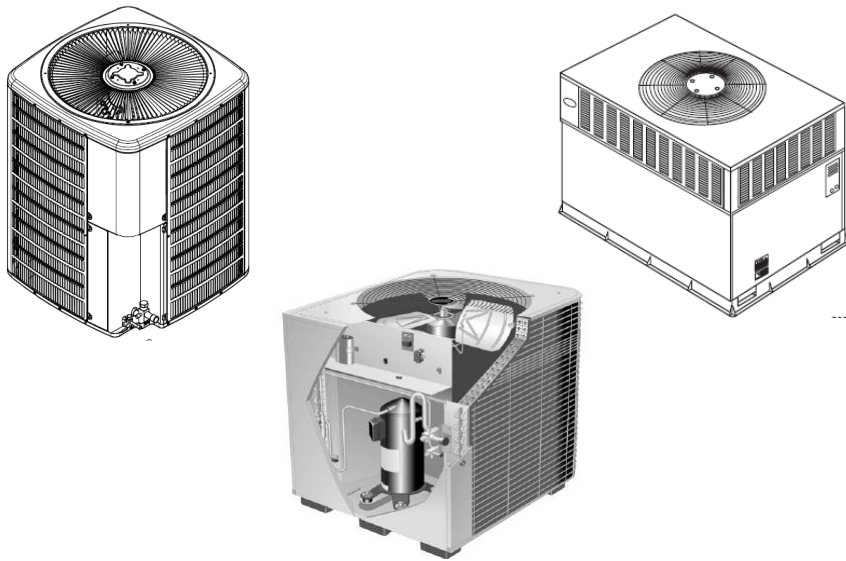

3. METERING DEVICE:





The metering device changes the pressure of the refrigerant as it passes through by restricting the amount of flow that can exit the outlet. There is high pressure liquid on the inlet side of the metering device and low pressure liquid on the outlet side.

Because of the restrictive capability of the metering device, the refrigerant will start to vaporize as it exits the metering device.

Metering Devices:

These are the types of metering devices that you will encounter on most systems.

1. Capillary tube
2. TXV
3. Fixed Orifice

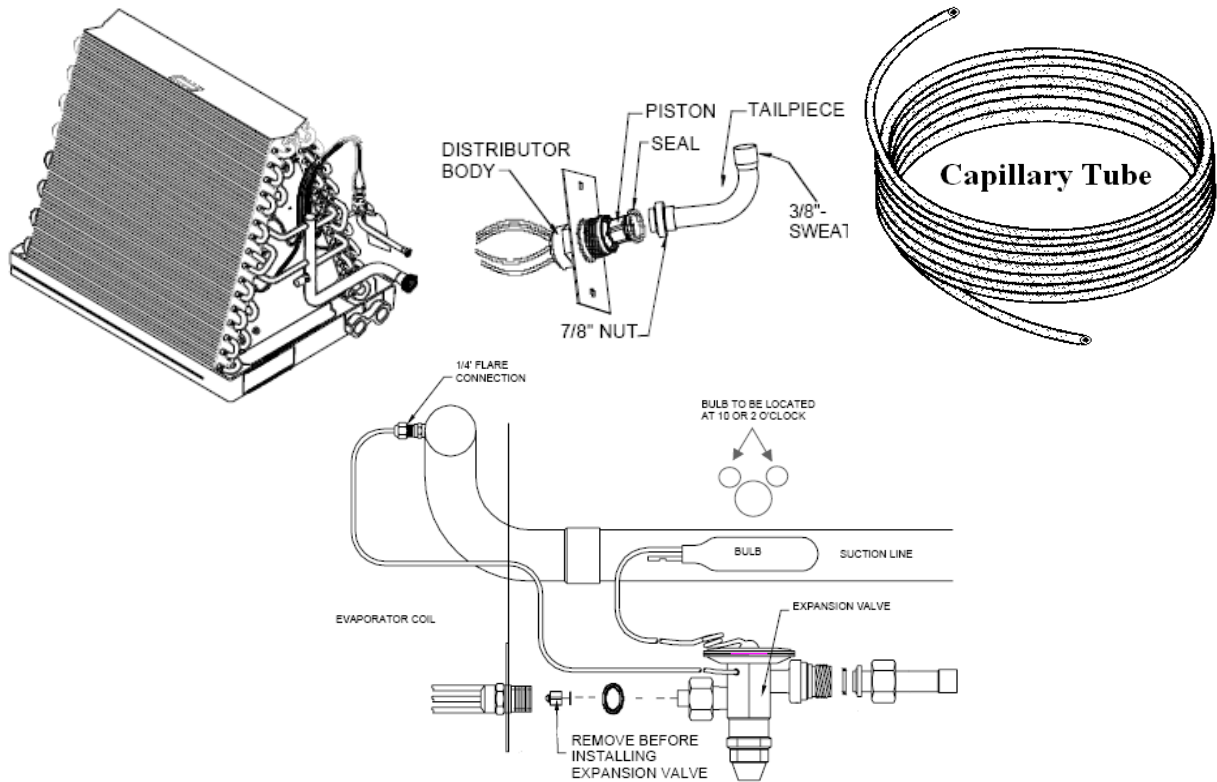

4. EVAPORATOR:

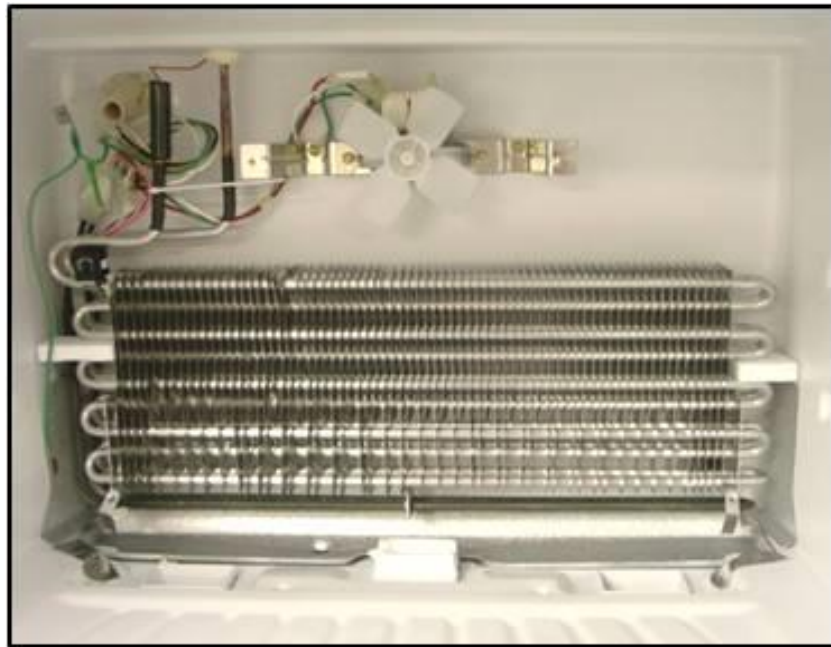

The evaporator is the area where the low-pressure liquid refrigerant is delivered from the metering device and by changing the size of the space from the outlet of the metering device to the inside of the evaporator, the refrigerant vaporizes.

As the refrigerant vaporizes or boils off, it absorbs heat from the surrounding air or direct contact with food products that may be touching the evaporator in some applications.

All of the heat that is removed from the refrigerator / freezer has to travel through the evaporator and into the refrigerant so it can be pulled out of the area by the pumping action of the compressor.

Evaporators:

There's about the same amount of types of evaporators as there were condensers.

1. Forced - Air
2. Static
3. In - Wall

Refrigerator evaporators - the plate types are almost all gone.

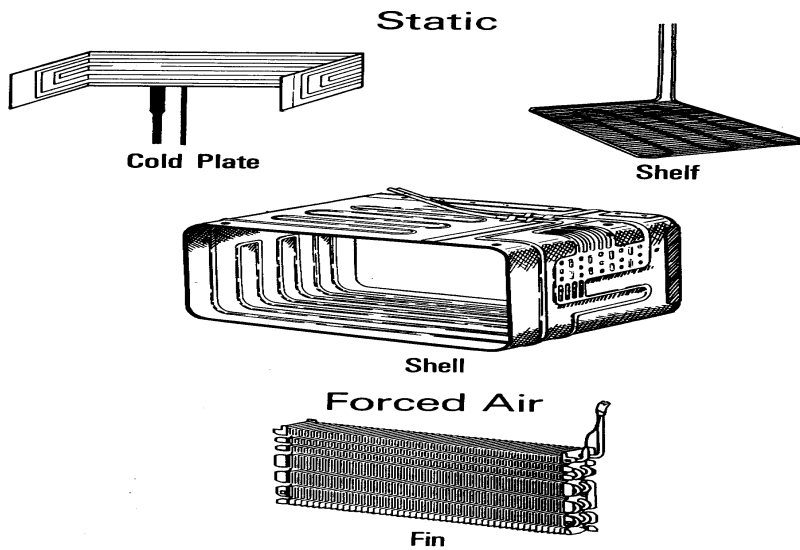

Typical Air - Conditioning evaporator:

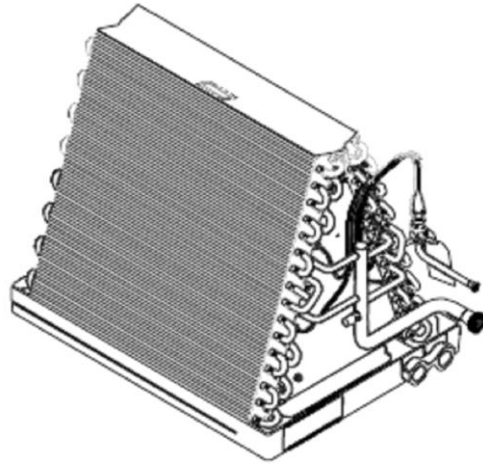

Most refrigeration systems have more components than the four listed previously. Other components that could be found in a refrigeration system include but not limited to:

1. Pre Cooler
2. Oil Cooler
3. Filter Drier
4. Refrigerant Flow Control Valve
5. Accumulator
6. Heat Exchanger

The need and arrangements of these additional components would depend on the system and the manufacturer.

Additional Components:

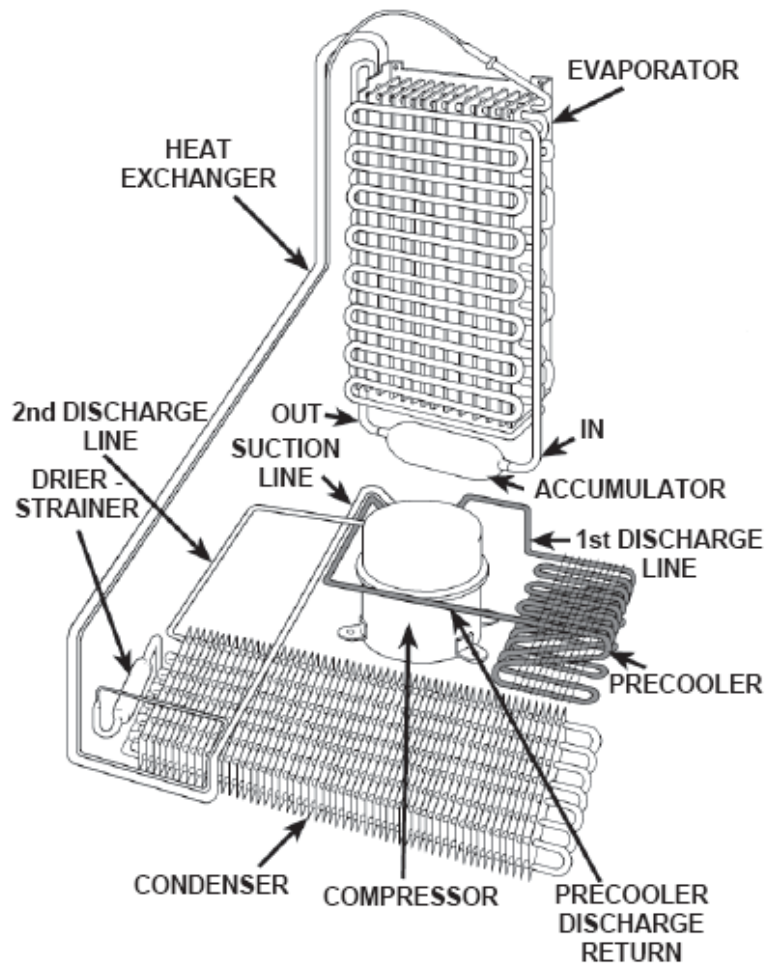

System Component Servicing

Most system components on Sealed Systems have to be serviced by Soldering and/or Brazing.

A common propane torch is not hot enough to braze and in most cases soldering is not substantial to hold a system together.

The common practice is to use either an Acetylene/Air mix or Oxygen/Acetylene. Jobs on larger tubing like air conditioning systems and because of being outdoors require Oxygen/Acetylene.



Oxy – Acetylene torch



Gas – Air mix torch



Dual tip for brazing small tubes

When soldering or brazing, you should push nitrogen through the tubing to eliminate oxidation of the tubing on the inside. The nitrogen should not be under pressure, just enough to present a presence in the tubing. In most cases you can purge nitrogen through the system to push out the remnants of refrigerant and displace the refrigerant with nitrogen.

If you are brazing on a refrigeration system and see a Green flame, back away, you are burning refrigerant and creating Phosgene Gas which is highly toxic and can overcome you quickly and kill you.

Soldering and Brazing jobs when servicing refrigeration systems will require you to have skills developed in connecting various types of tubing together. Some examples are;

- Copper to Copper – relatively easy
- Copper to Steel – relatively difficult – must be clean and you must use an acid type flux to eliminate oxidation
- Copper to Aluminum – very difficult – most resort to epoxy or factory connections (ordering the parts preassembled).

Today a lot of servicers doing sealed system repairs are using a compression type fitting that is hydraulically compressed together by hand or machine.



Compression fittings



Compression tool

Servicing system components also necessitates you knowing how to utilize special equipment to be able to properly perform servicing procedures.

You should refer to System Servicing Training information to be able to correctly connect gauges, vacuum pumps and service equipment to the system as in the example below.

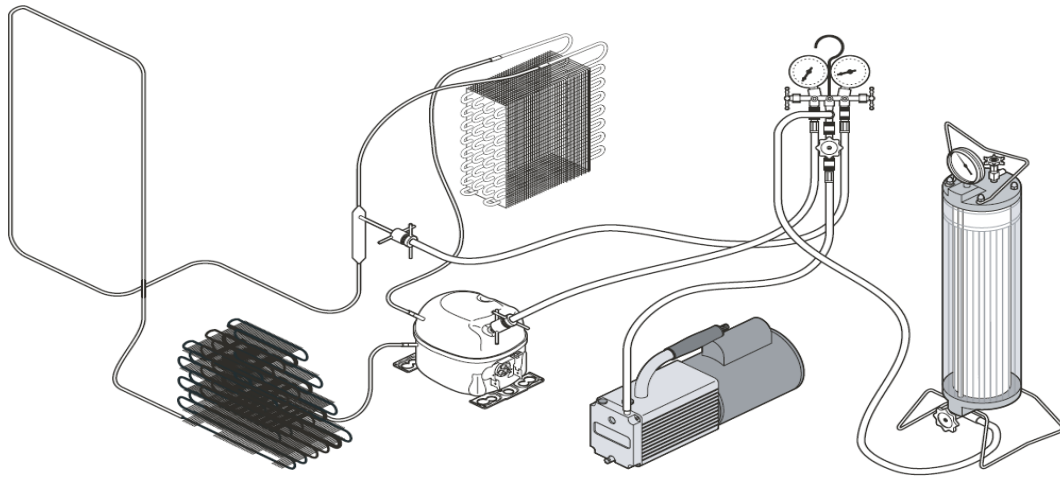

You should also become familiar with how to properly connect recovery equipment to the system to be able to perform recovery procedures to protect the environment and meet federal guidelines.

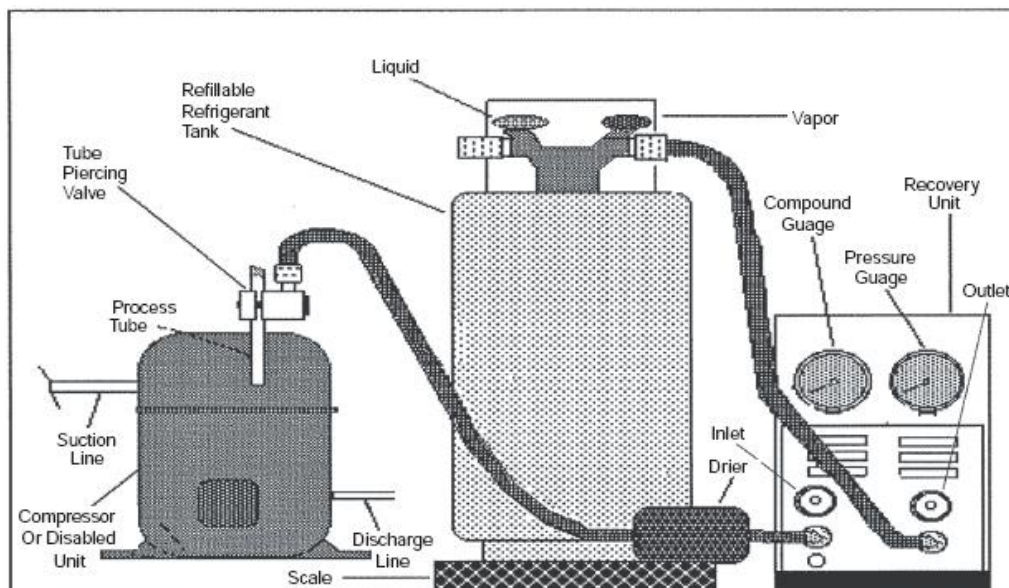

Refrigerants

Refrigerants are heat-carrying mediums which absorb heat at a low pressure and can be compressed to a higher pressure where they are able to give off the absorbed heat.

Refrigerant Characteristics:

R - 12 color code for cylinders White
 Boils at -21° F and has the ability to absorb
93 BTUs per pound vaporized.

R - 22 color code for cylinders Green
 Boils at -41° F and has the ability to absorb
90 BTUs per pound vaporized.

R - 134a color code for cylinders Lt Blue
 Boils at -15° F and has the ability to absorb
90 BTUs per pound vaporized.

R - 410a color code for cylinders Pink
 Boils at < -50° F and has the ability to absorb
98 BTUs per pound vaporized.

R-600a color code for cylinders Orange
 Boils at 11°F and has an Enthalpy rating of

376 compared to **216** for R-134a and **163** for R-12 which means it will absorb more BTUs than the others.

Refrigerant conditions:

High Side		
Vapor	*	
Saturated Vapor	*	
	>>>>	Condensing
Saturated Liquid	*	

Liquid	*	
Low Side		
Liquid	*	
Saturated Liquid	*	
	>>>>	Evaporating
Saturated Vapor	*	
Vapor	*	

By understanding the refrigerant conditions within the system you can establish what happens as the pressure is increased and decreased on the refrigerant and how the physical properties change with the change in pressure.

These changes illustrate the changes in temperature and changes in state that the refrigerant goes through in the process of absorbing heat and expelling heat.

Now we have established a Temperature / Pressure relationship of the refrigerant.

On the following page, identify the conditions of the refrigerant as it flows through a refrigeration system.

Place the number corresponding to the physical conditions of the refrigerant.

1. High Pressure Vapor	5. Low Pressure Liquid
2. High Pressure Saturated Vapor	6. Low Pressure Saturated Liquid
3. High Pressure Saturated	7. Low Pressure Saturated

Liquid	Vapor
4. High Pressure Liquid	8. Low Pressure Vapor

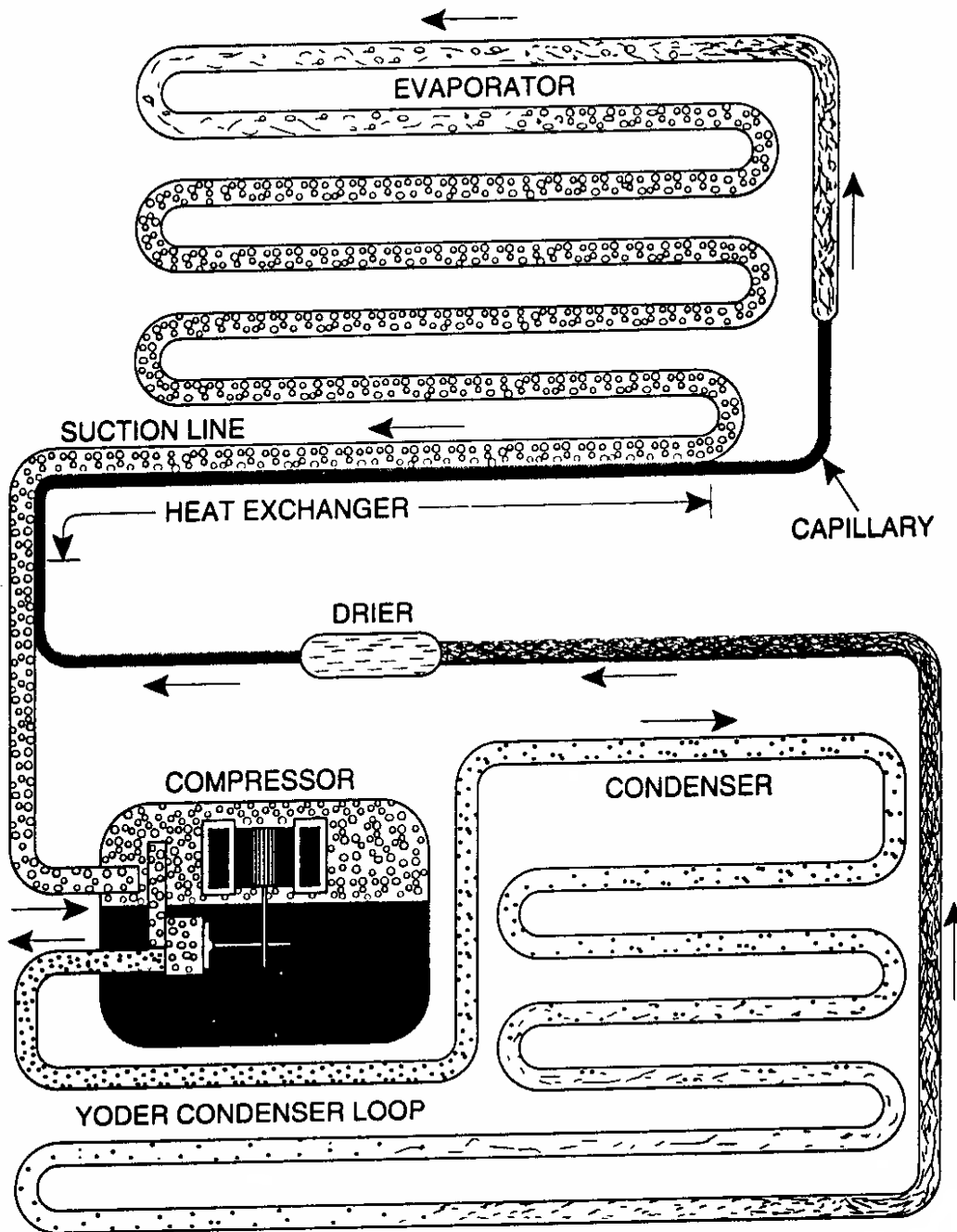

ir

flammability and their toxicity.

Classification and Grouping as expressed by ARI, OSHA and the EPA:

- Class 1 - Group 1 - Non-Flammable
- Class 2 - Group 2 - Somewhat Flammable
- Class 3 - Group 3 - Flammable

Class A - Group A - Non-Toxic

Class B - Group B - Toxic

Per the classification and grouping above, a refrigerant rating of

1-A would be the safest.

Operating Pressures:

Operating pressures will vary with the temperature of the condensing unit, amount of condenser surface, operating back-pressure, condition of the condenser surface, extent of superheating of the refrigerant gas, and some other extreme factors.

Two of the factors that affect the operating pressures and system performance are **Superheat** and **Subcooling**.

What is Superheat and Subcooling?

Superheat:

The amount of heat that the refrigerant picks up, as it travels through the evaporator, beyond its saturation point (Boiling Point) at a given pressure.

Subcooling:

The amount of heat that the refrigerant loses, as it travels through the condenser, beyond its saturation point (Point of Fusion) at a given pressure.

Operating pressures cont.:

Below are some of the normal operating pressures found in refrigerator / freezers and air conditioning systems using the most common refrigerants.

Refrigerator / Freezer using R-12 refrigerant	
High Side- 90 to 110 psi	Low Side- 5”vac to 8 psi
Refrigerator / Freezer using R-134a	
High Side- 100 to 120 psi	Low Side- 8”vac to 6 psi
Air Conditioner using R-22	
High Side- 225 to 250 psi	Low Side- 65 to 71 psi
Air Conditioner using R-410a	
High Side- 355 to 395 psi	Low Side- 115 to 125 psi
<i>* These numbers are based on an average temperature day and normal operating conditions.</i>	

Refrigerants should not be mixed at the field level. Some refrigerants are mixed at the manufacturing level to build other refrigerants with varying capabilities.

When refrigerants are mixed at the field level they become contaminated.

Refrigerants can also become contaminated with debris from field applications and poor servicing practices.

Pressure / Temperature relationship:

Since refrigerants are used in sealed environments, they exhibit varying pressure / temperature characteristics.

With a refrigerant in a sealed vessel without any outside intervention, the refrigerant will exhibit a specific pressure based on the temperature it is exposed to.

A good example of temperature / pressure relationship would be water. Water at standard atmospheric pressure boils at 212 degrees F. If we were to create a change in pressure other than atmospheric pressure, the characteristics of the water would change. If we were to raise the pressure on a container of water the boiling point of the water would change, inversely, if we were to lower the pressure on a container of water, it would again change the boiling point of the water.

Can water boil at room temperature?

YES _____ **X** _____ NO _____

Example of a temperature / pressure reference card:

VAPOR PRESSURE, PSIG									
Temp°F	11	12	22	113	114	500	502	134a	123
-50	28.9	15.4	6.2	—	27.1	12.8	0.2	18.7	29.2
-45	28.7	13.3	2.7	—	26.6	10.3	1.9	16.9	29.0
-40	28.4	11.0	0.5	—	26.0	7.6	4.1	14.8	28.9
-35	28.1	8.4	2.6	—	25.4	4.6	6.5	12.5	28.7
-30	27.8	5.5	4.9	29.3	24.6	1.2	9.2	9.8	28.4
-25	27.4	2.3	7.4	29.2	23.8	1.2	12.1	6.9	28.1
-20	27.0	0.6	10.1	29.1	22.9	3.2	15.3	3.7	27.8
-15	26.5	2.4	13.2	28.9	21.8	5.4	18.8	0.1	27.4
-10	26.0	4.5	16.5	28.7	20.6	7.8	22.6	1.9	27.0
-5	25.4	6.7	20.0	28.5	19.3	10.4	26.7	4.1	26.5
0	24.7	9.1	23.9	28.2	17.8	13.3	31.1	6.5	25.9
5	23.9	11.8	28.2	27.9	16.2	16.4	35.9	9.1	25.3
10	23.1	14.6	32.8	27.6	14.4	19.7	41.0	11.9	24.6
15	22.1	17.7	37.7	27.2	12.4	23.3	46.5	15.0	23.7
20	21.1	21.0	43.0	26.8	10.2	27.2	52.5	18.4	22.8
25	19.9	24.6	48.7	26.3	7.8	31.5	58.8	22.1	21.8
30	18.6	28.4	54.9	25.8	5.2	36.0	65.6	26.0	20.7
35	17.2	32.5	61.5	25.2	2.3	40.8	72.8	30.3	19.5

Refrigeration System Troubleshooting

Proper diagnosis of any sealed system begins with a thorough understanding of its normal operating characteristics. Deviations from the norm alert the technician to the possibility of a system malfunction.

The system often reacts to external forces in such a manner that makes it appear that a system failure has occurred. In reality, the system is behaving exactly as it should for the conditions that it encounters.

Things that affect system operation are;

- **Environment**
- **Loading Requirements**
- **Operating Voltage**
- **Improper Voltage**
- **Air Movement**

and these are just to name a few.

System Operating Characteristics:

The following sheets give you the characteristics of a typical system with some various system problems.

System Operating Characteristics:

Normal Operating Cycle

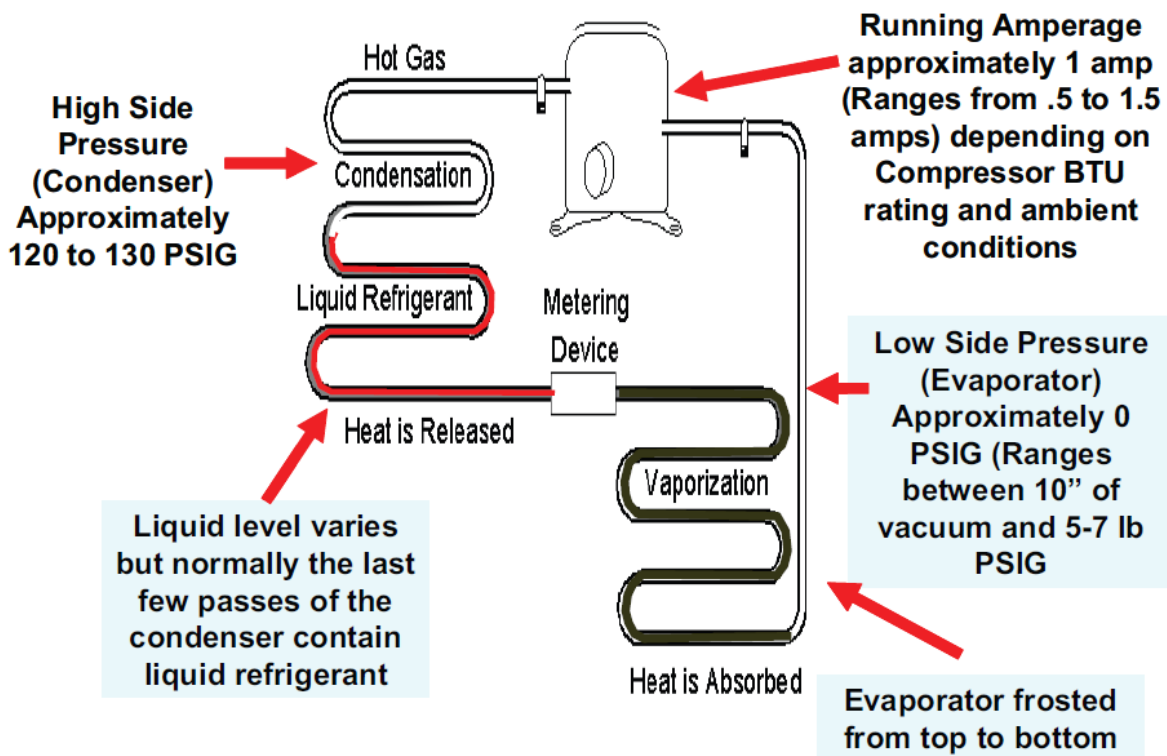

Low Side pressure - between 10'' vac and 5 to 7 psi

High Side pressure - between 120 to 130 psi

Fresh Food temp. - 38°F, =/- 3°

Freezer temp. - 0°F, =/- 3°

Leak: Refrigerant left in System

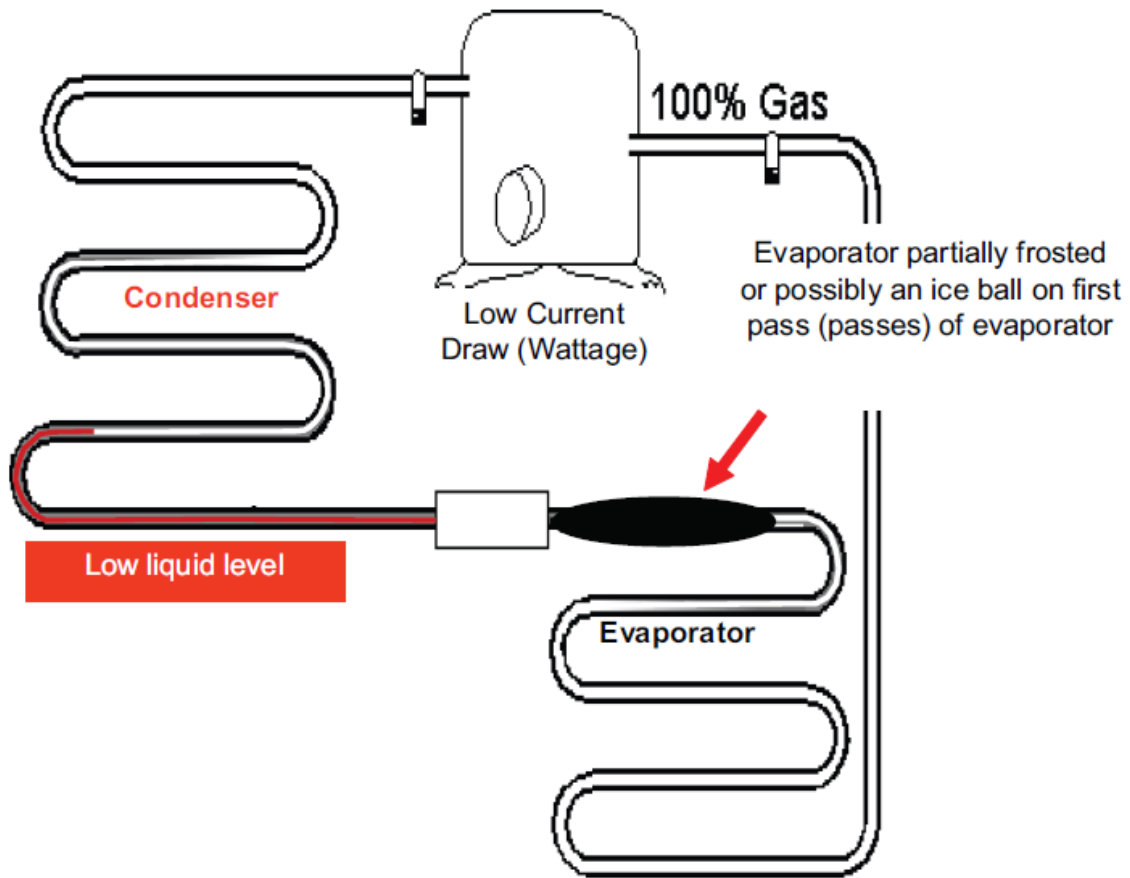

High Side Leak: No refrigerant in the system

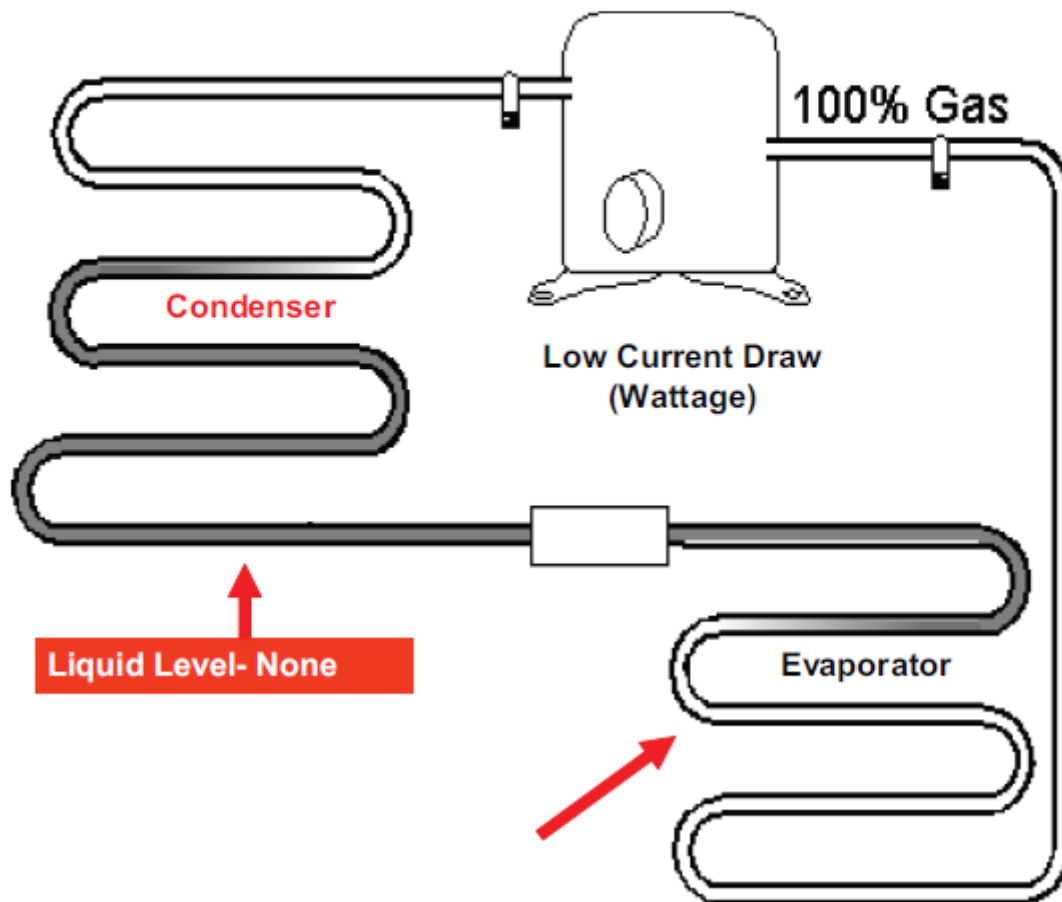

Low Side Leak: Air in the system

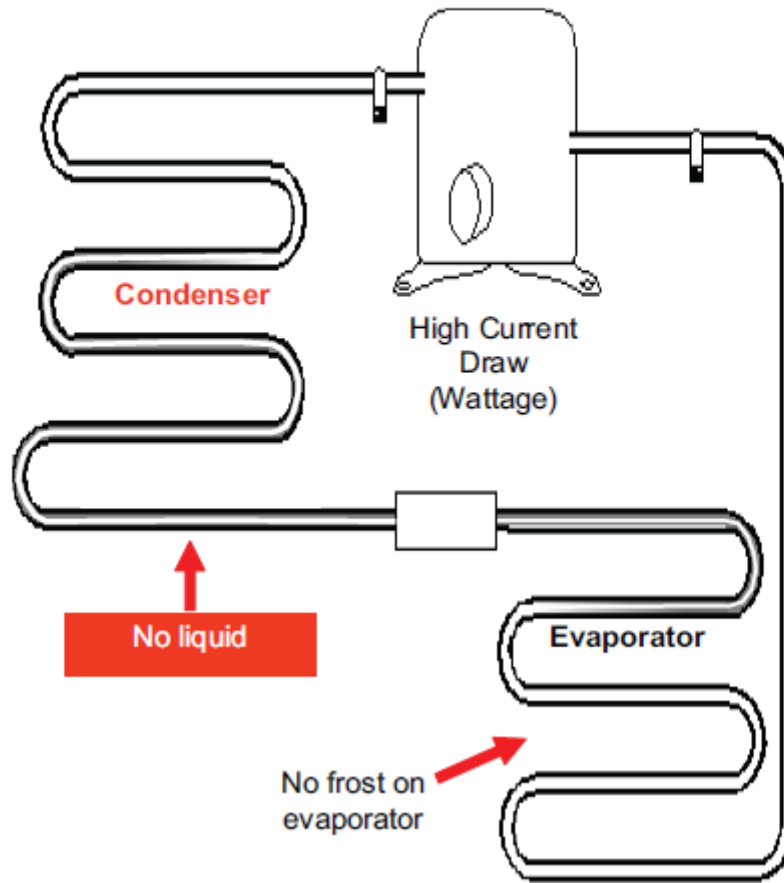

Undercharge

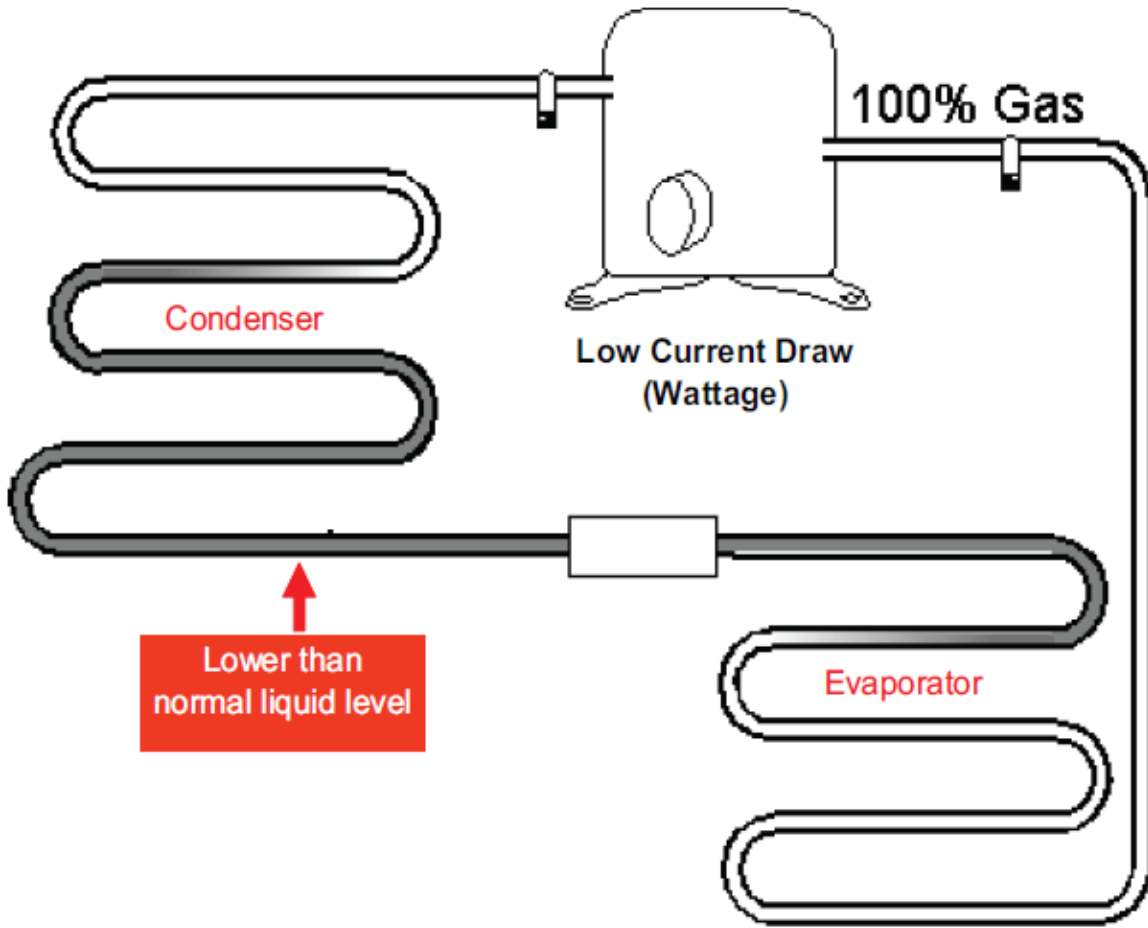

Complete Cap Tube Restriction

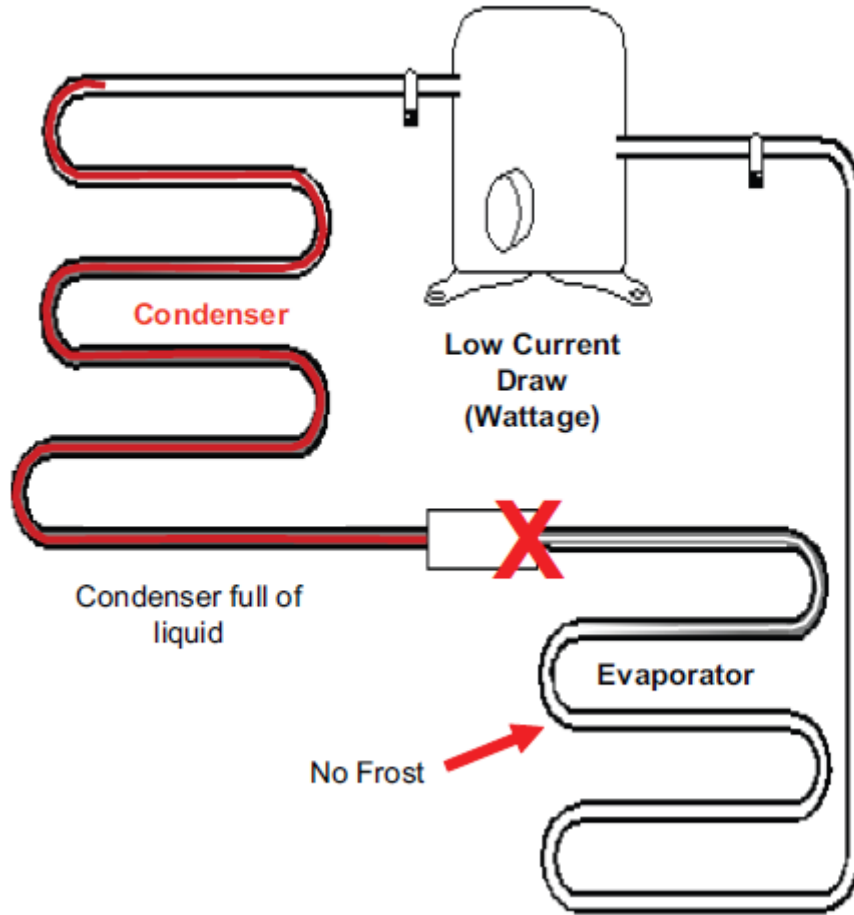

Inefficient Compressor

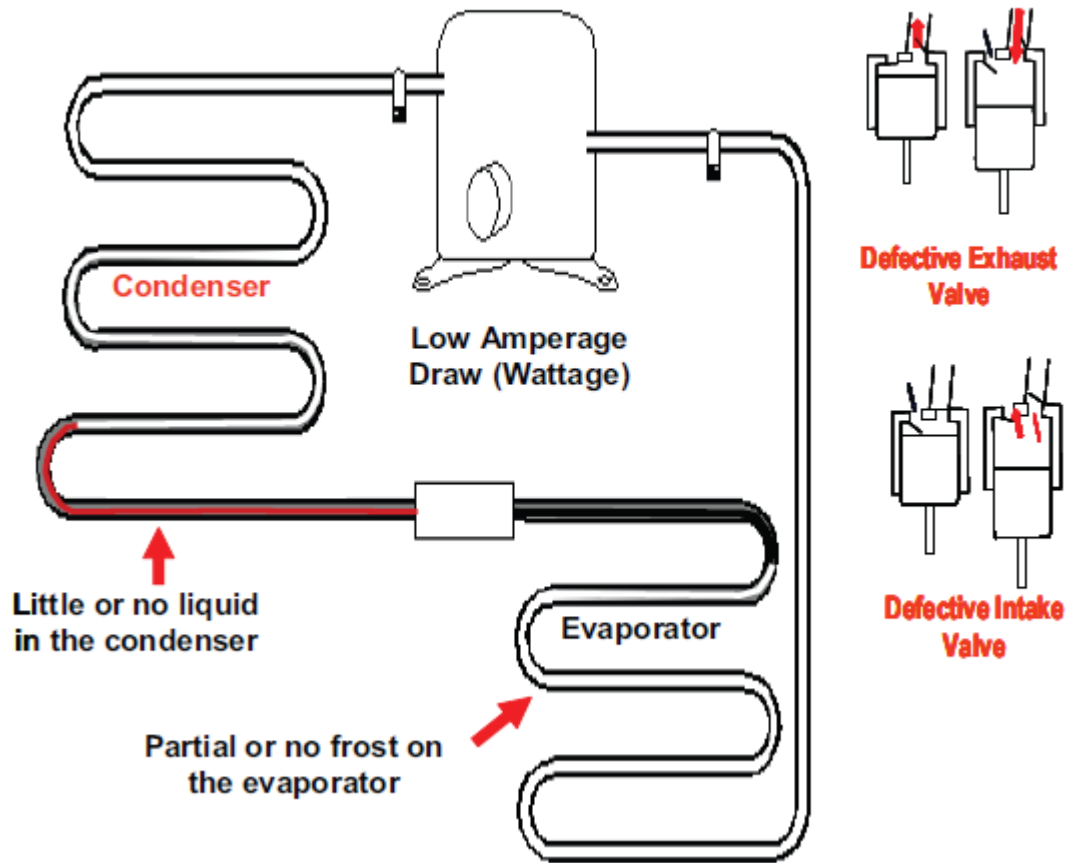

Overcharged System

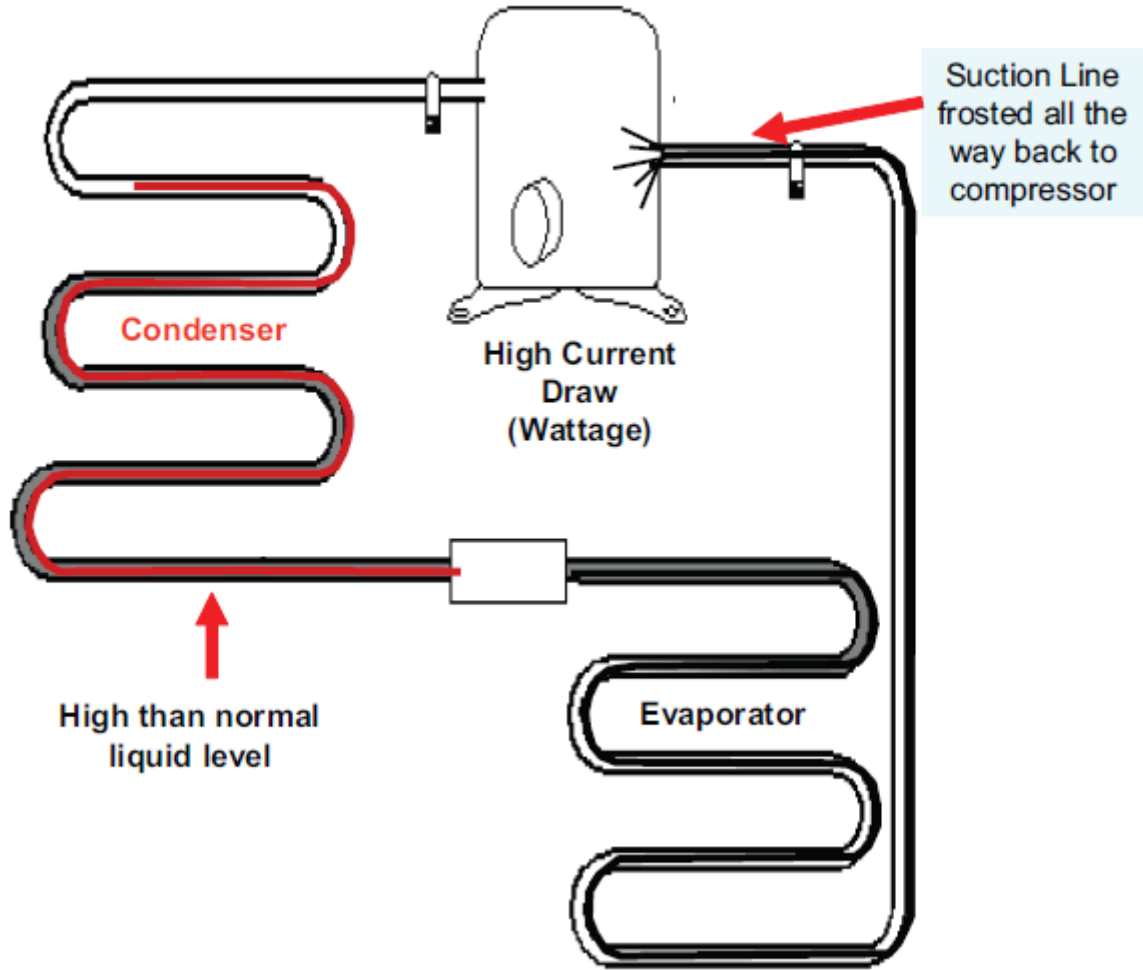

Sealed System Failures

Conditions	Indicators							
	Amps - Watts	Condenser Temp	Condenser Liquid Level	Frost Line	Compressor discharge Temp	Low Side Pressure	High Side Pressure	Pressure Equalization Rate
Overcharge	High	Higher than Normal	Higher than Normal	All the way back to suction line	Hot	Higher than Normal	Higher than Normal	Normal to slightly longer
Undercharge	Low	Lower than Normal	Lower than Normal	Partial	Cooler than normal	Lower than Normal	Lower than Normal	Quicker than Normal
Low-Side Leak- Refrigerant in System	High *	Normal to Slightly Higher*	Lower than Normal	Partial to Non existent (possible frost ball)	Cooler than normal	Normal to slightly higher*	Normal to slightly higher than Normal *	Normal
Low-Side Leak NO Refrigerant in System	High	High	None	Non existent	Hot	Atmospheric	Higher than Normal	Normal
High Side Leak	Low	Low	Low to non existent	None	Cooler than normal	Vacuum	Low	Quicker than Normal
Low Capacity Compressor	Low	Low	Low	Partial to Non existent	Cooler than normal	Higher than normal	Lower than Normal	Quicker than Normal
Restrictions								
Capillary Tube (Complete)	Low	Low	Higher than normal	None	Cooler than normal	Vacuum	Ambient	No equalization
Capillary Tube (Floating)	Low	Low	Higher than Normal	Intermittent	Intermittently cooler than normal	Intermittent Partial Vacuum	Intermittent lower than normal	Intermittent

* Exact conditions dependent on level of non condensables in the system

Restricted Condenser Airflow

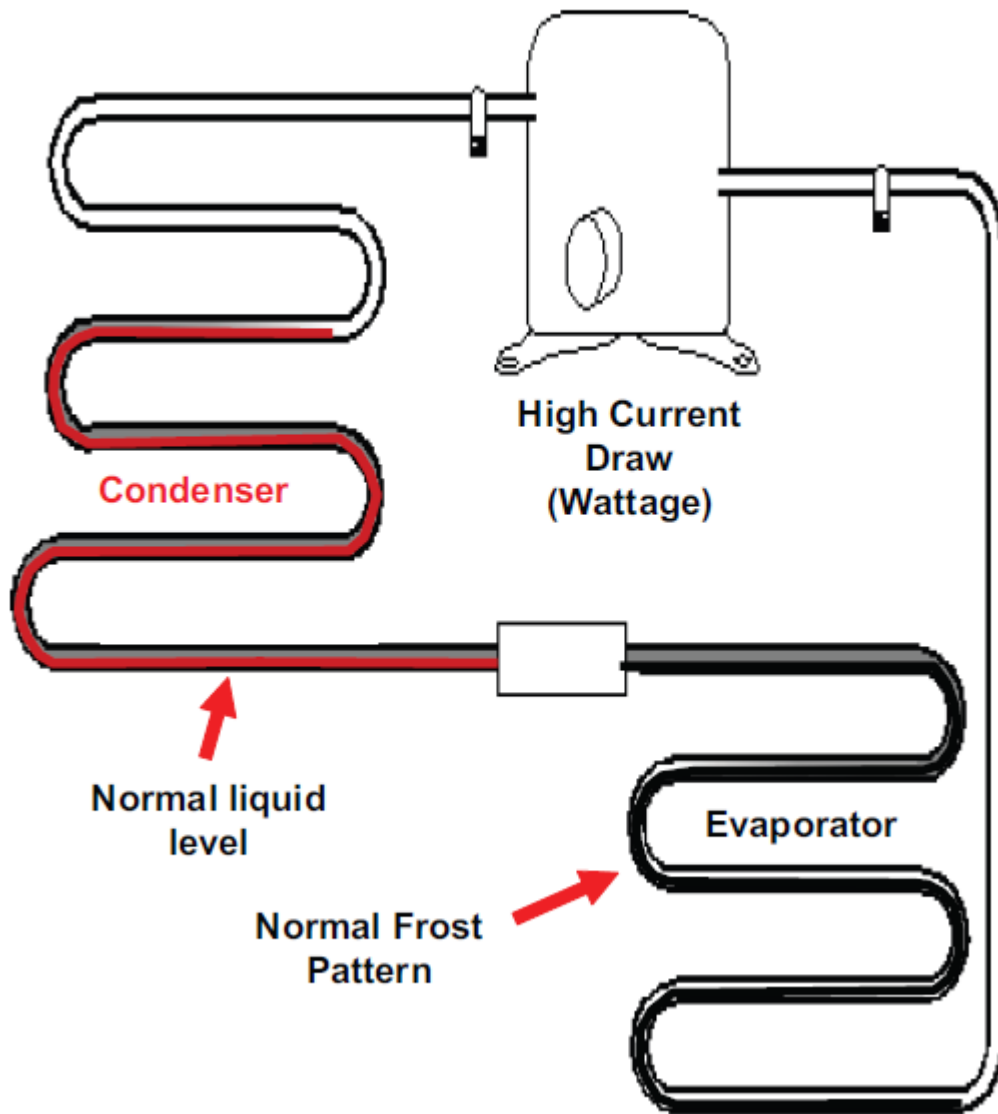

Conditions that Mimic Sealed System Failure Chart

Conditions	Indicators							
	Amps - Watts	Condenser Temp	Frost Line	Compressor discharge line temp	Low Side Pressure	High Side Pressure	Fresh Food Temp	Freezer Temp
Plugged condenser	High	Higher than Normal	Full	Higher than normal	Higher than Normal	Higher than Normal	Warmer than Normal	Warmer than Normal
Blocked Cond. Fan	High	Higher than Normal	Full	Higher than normal	Higher than Normal	Higher than Normal	Warmer than Normal	Warmer than Normal
Blocked Evap Fan	Low	Lower than Normal	Frost back to compressor	Lower than normal	Lower than normal	Lower than Normal	Warmer than Normal	Warmer than Normal
Evap Iced up (defrost failure)	Low	Lower than Normal	Frost back to compressor	Lower than normal	Lower than normal	Lower than Normal	Warmer than Normal	Warmer than Normal
High heat load	High	Higher than Normal	Full	Higher than normal	Higher than normal	Higher than normal	Warmer than Normal	Warmer than Normal
High ambients	High	Higher than Normal	Full	Higher than normal	Higher than normal	Higher than normal	Warmer than Normal	Warmer than Normal
Damper failed closed	Low	Lower than Normal	Full	Lower than normal	Lower than normal	Lower than normal	Warmer than Normal	Cooler than Normal
Damper failed open	Slightly higher than Normal	Slightly higher	Full	Normal	Slightly higher than normal	Normal	Cooler than Normal	Normal to slightly Warmer

Page left
blank

EPA & Refrigerant Recovery

The EPA requires anyone that services refrigeration systems to be certified for Refrigerant Usage by passing an exam that covers:

- Stratospheric Ozone Protection information
- Refrigerant Usage criteria
- System Operation & Servicing techniques
- EPA Refrigerant Recovery criteria
- Established levels of recovery based on system size and refrigerant used in the system
- Overall recovery techniques and requirements

Core - For any certification, everyone must pass the core information section which covers background information for refrigerants and global concerns for ozone depletion.

The following are levels of certification as outlined by the EPA:

Type I - Anyone servicing systems that contain less than 5 lbs of refrigerant and is factory sealed.

Type II - Anyone servicing systems with High Pressure refrigerants

Type III - Anyone servicing systems with Low Pressure refrigerants

Universal - Passed all sections listed above

EPA Requirements:

All Refrigerant must be recovered.

EPA terminology

Recovery – the process of removing refrigerant from an existing system and ensuring the remnants of refrigerant are at or below established levels.

Recycle – the process of removing refrigerant from an existing system and then re-charging that refrigerant back into the system once it has been repaired – must not change ownership.

Reclaim – the process of removing refrigerant from an existing system, cleaning and bringing the refrigerant back to like-new quality and then re-using it. Normally requires a laboratory.

TABLE 4

Required Levels of Evacuation for Appliances Except for Small Appliances, MVACs, and MVAC-like Appliances

Type of Appliance	Inches of Hg Vacuum ¹ using recovery or recycling equipment manufactured or imported:	
	Before November 15, 1993	on or after November 15, 1993 ²
HCFC-22 appliance, or isolated component of such appliance, normally containing less than 200 pounds of refrigerant.	0	0
HCFC-22 appliance, or isolated component of such appliance, normally containing 200 pounds or more of refrigerant	4	10
Other high-pressure appliance, or isolated component of such appliance, normally containing less than 200 pounds of refrigerant (CFC-12, -500, -502, -114)	4	10
Other high-pressure appliance, or isolated component of such appliance, normally containing 200 pounds or more of refrigerant (CFC-12, -500, -502, -114)	4	15
Very high-pressure appliance (CFC-13, -503)	0	0
Low-pressure appliance (CFC-11, HCFC-123)	25	25 mm Hg absolute ³

¹ at standard atmospheric pressure of 29.9 inches Hg

² this equipment must be certified by an EPA-approved equipment testing organization

³ note that 25 mm Hg absolute is equal to 29 inches Hg (within 1 inch of perfect vacuum)

TABLE 5**Recovery Requirements for Small Appliances**

Recovery Device Date Of Manufacture	State Of Compressor	% Of Charge	Or	Level Of Vacuum
Before November 15, 1993	Running or Not	80%		
On or after November 15, 1993	Not Running	80%	or	4 inches Hg vacuum
	Running	90%		

In preparation for the EPA Certification exam, you should study the important dates concerning refrigerant usage, recovery, prohibition on venting refrigerant as well as important aspects of servicing refrigeration systems.

Most study guides give you the information listed above and most include a practice test that gives a person insight into but not the actual questions on the exam.

Questions?